Point-and-Shoot Data

Stephanie Lin
Harvard University
Graduate School of Design
slin1@gsd.harvard.edu

Shaun Salzberg
Massachusetts Inst. of Tech.
Media Lab
salzberg@media.mit.edu

Samuel Luescher
Massachusetts Inst. of Tech.
Media Lab
luescher@media.mit.edu

Hiroshi Ishii
Massachusetts Inst. of Tech.
Media Lab
ishii@media.mit.edu

Travis Rich
Massachusetts Inst. of Tech.
Media Lab
trich@media.mit.edu

Abstract

We explore the use of visible light as a wireless communication medium for mobile devices. We discuss the advantages of a human perceptible communication medium in regards to user experience and create tools for direct manipulation of the communication channel.

Author Keywords

Visible light communication, wireless communication, optical communication

ACM Classification Keywords

H.1.2 [User/Machine Systems]: .

General Terms

Design, Human Factors

Introduction

The realm of wireless communications has primarily, by design, been confined to invisible radio waves. This limits a user's ability to understand what data signals are, how they carry information, how their performance can be modified, or how broken communication links can be debugged. In certain applications, a visible communications medium may provide a more intuitive and meaningful user experience. To explore this concept, we use visible light to transmit information due to its deeply

rooted role in human perception and non-verbal communication.

Visible light has been used as a means of communication for many different purposes in prior work, though few focus on its impact on human-computer interaction. The use of light as a communication medium is a technique first seen in modern technology in 1880 with Alexander Graham Bell's photophone: a device that converts acoustic waves to optical modulation for transmitting voice signals [1]. Of more interest, since the early 2000s, many academic groups have explored modulating solid-state lighting as a means for digital communication, namely Keio University's Nakagawa Lab[5], the Boston University Smart Lighting Center [6], and the Omega Project [8]. However, much of this work has focused on augmenting existing infrastructure-based wireless communication systems (e.g. WiFi) for technical performance reasons, rather than human experience motivations.

Furthermore, the IrDA [4] (Infrared Data Association) has performed substantial work in defining standards and protocols for wireless communication using infrared-range optics. While many of the technical details from this work can be applied to the study of visible-light communication, the influence of a human-perceptible communication medium on user experience metrics remains unexplored.

Simultaneously, there has been growing interest in the realm of materiality as it relates to HCI concepts and principles. Applying the groundwork laid by Dourish [3], Vallgård [7], and others, we can explore the use of light from the perspective of the material properties it exhibits. Our ability to interact with and experience light allows additional physical properties with which to design communications applications.

To that end, we take a focused look at mobile device communication. Specifically, we present an Android application and associated hardware that wirelessly transmit data between two mobile phones using modulated light. We also explore several affordance tools for the devices that give users the means to directly manipulate the communication medium. The tools enable a physical interaction that allows for intuitive communication channel modifications relating to security, privacy, broadcast range, and network privileging.

Understanding how a visible communication medium influences the humans perception of wireless data poses significant opportunities for new behaviors and applications with wireless data exchange.

Implementation

The implementation of our light-based communication channel for mobile devices can be organized into four categories: communication technology, user-interface software, hardware enclosure, and affordance tools.

Communication Technology

The communication technology consists of the transmitting and receiving hardware, the device-hardware interface, and the software-implemented communication protocol. The underlying principle of visible light communication is that an LED is modulated at high rates (above human perception). That is, the intensity of the light emitted from the LED changes as a function of time. A light sensitive photodiode device is then used to sense these changes in light intensity. For a simple digital communication system, an LED in the 'on' state can represent a binary 1, while an LED in the 'off' state can represent a binary 0.

The transmitting hardware is a Wilson current mirror

created using Zetex high-speed transistors. The current mirror drives a string of white LEDs connected in series. With no load, the simple current mirror design is shown to switch at rates above 10MHz.

The receiving hardware uses a two-stage circuit. The first stage is comprised of a transimpedance amplifier, designed to take the current output of the photodiode and convert it to a voltage on the order of mV. The second stage is a simple negative feedback amplifier with a gain of 100. The output of these two stages is a signal, typically between 5-12V peak-to-peak, that corresponds to the modulation of the incident LED illumination.

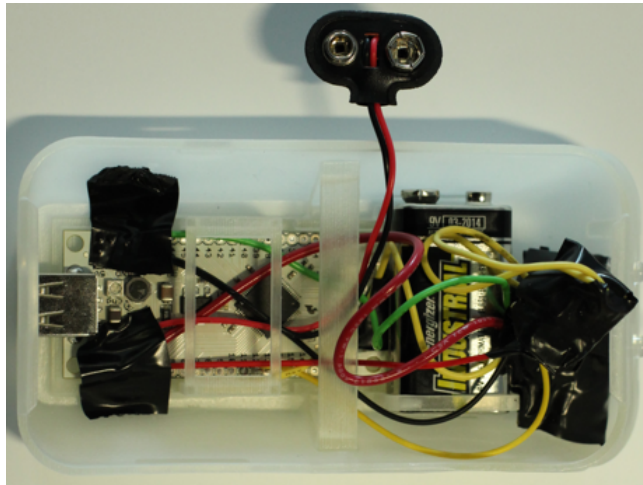

Figure 1: System electronics and power supply contained in the phone enclosure.

The hardware interfaces to an off-the-shelf IOIO board: an Arduino-based prototyping platform that allows native Android applications to communicate with hardware peripherals via the mini-USB port [2]. The light signal is

received at a digital input pin on the IOIO board, and interpreted as a binary value. Our use of the IOIO board as an interfacing device constrains our current prototype to Android-capable devices, though the set up could easily be ported to iOS and other mobile devices by alternatively using the audio jack for communication. Here, we use Samsung Galaxy S Vibrant phones.

The communication protocol is a simple UART serial protocol, in which the LED driver is hooked up to the IOIO board's Tx port and the photodiode circuit to the Rx port. The application and serial protocol are written in Java, installed on the Android phone, and then communicated through the USB connection to the IOIO board.

User-Interface Software

The physical interaction with the communications medium is one of vital interest to this project. Thus, the interaction with the software abstraction of the data carried on that medium is also highly important. We design the user interface to match the intuitive human interactions that are enabled by using visible light. Our prototype is a simple note-passing application that employs a sliding motion to 'push' the data from one device to another, in much the same way that a person can physically slide or push a note to a nearby friend. This motion takes advantage of both the directionality and physicality of our light-based communications medium.

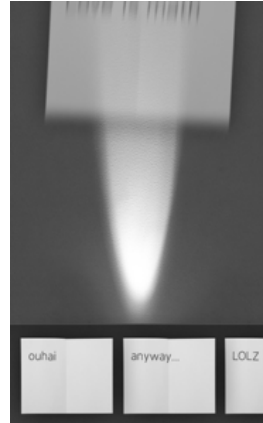

Figure 2: Messaging app as a note is being transmitted. Note the simulated light beam that matches the physical light being emitted from the device.

On-screen, we display a virtual light beam when data is being transmitted to the recipient. This is to further give users a clear understanding of how their data is being sent and to indicate to them that they can point and shoot at the recipient as if it were a flashlight.

Hardware Enclosure

We fabricate an enclosure to contain the hardware. The enclosure features an interface that allows physical affordance tools to be placed in front of the LED and photodiode. The enclosure is designed to fit the Samsung Galaxy S Vibrant phone and is 3D printed using an Invision S12 printer.



Figure 3: Final system contained within phone enclosure

Affordance Tools

We create and explore a series of affordance tools to enable the user to directly manipulate the communication medium. We take advantage of lenses, filters, and mirrors in our design. While the tools created are not designed as a statement regarding optimal human interaction design, they demonstrate the ability of a user to directly manipulate the communication channel. Further design work on optimizing usability is needed.

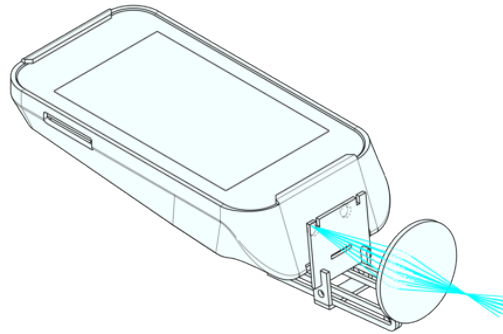

Figure 4: Focus tool that allows users to change the width of the emitted communication beam.

We first present a lens-based focusing and defocusing tool to allow the user to control the width of the light beam emitted from the device. This allows users to change the communication channel from a broadcast channel (defocused) to a private peer-to-peer channel (focused) and vice-versa.

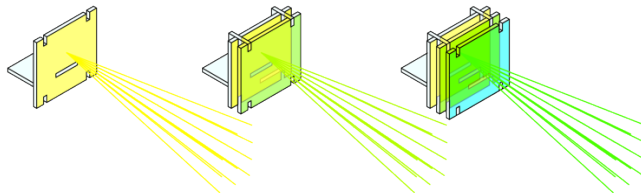

Figure 5: Filter tools that enable separate color-based channels of communication.

We also explore a color filter that allows users to create separate communication channels. The filters can be placed in front of both the transmitter and receiver such that a device can, for instance, select to listen to only a

blue or red channel. White light may then be considered a 'public' channel.

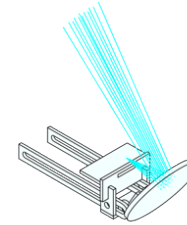

Figure 6: Mirror tool that enables the data medium to be arbitrarily redirected.

Finally, we present a mirror that allows users to redirect the light beam in any arbitrary direction.

Furthermore, it should be noted that the user's body is a very important mechanism for controlling the communication medium. The hand can be used to cover the LED (blocking all transmission) or cover the photodiode (blocking all incoming data). This natural behavior maps intuitively to how people interact with physical information written on paper or a computer screen; private data can easily be covered by a hand or turned away from peering parties.

Discussion & Future Work

Visible light as a wireless communications medium has many interesting advantages in terms of user experience. The ability to see and interact with light makes it a readily understandable and controllable communication medium, offering benefits in ease-of-use, privacy, security,

and debuggability. With existing technologies such as WiFi and Bluetooth, users have to deal with the (often frustrating) details of configurations, passwords, and permissions. Point-and-shoot data, however, is as simple as aiming a flashlight.

An interesting feature that arises from physicalizing data transfer is the ability to engage in digital communications without needing to first obtain the senders' or recipients' digital IDs. Typically, to send digital information to someone, one needs a digital handle for that person – an email, a phone number, a URL, etc. The ability to point and shoot data, however, allows users to communicate digitally just as they would physically – that is, by simply approaching each other in a particular space and talking. If two devices are within line-of-sight of each other, they can communicate.

Recommended future steps include increasing the bandwidth of the communication channel and exploring applications beyond simple messaging. In regards to the communication bandwidth, we can rely on the framework created from prior work on infrared data communication. The IrDA has outlined standards, enabling wireless communication at speeds of 1Gb/s, that can be used as a model for improving the transfer speeds of a visible light system. Furthermore, we foresee a wide range of applications being developed that are well fit for a visible communication medium. Opportunities in gaming, peer-to-peer data sharing, and mobile payments are a few domains that we intend to explore.

Closer integration of the communication technology to the mobile device is also a necessary future step. One opportunity in regards to this goal is to use the audio port as the device interface (as opposed to the mini-USB port). This would provide a more universal connection and allow

such a system to be implemented on devices without mini-USB ports. A longer-term vision is that mobile devices will natively support light-based communication with built-in LEDs, eliminating the need for such device-to-external-hardware communication hacks.

Acknowledgements

We thank Professor Hiroshi Ishii and the Tangible Media Group for their insightful discussions and feedback.

References

- [1] A. G. Bell. Photophone-transmitter. Technical Report Patent #23549, USA, Dec 1880.
- [2] Y. Ben-Tsvi. *Meet IOIO - I/O for Android*, 2012. <http://ytai-mer.blogspot.com/2011/04/meet-ioio-io-for-android.html>.
- [3] P. Dourish and M. Mazmanian. Media as material: Information representations as material foundations for organizational practice. *Proc. Int. Symp on Process Organization Studies*, 2011.
- [4] IrDA. *Infrared Data Association*, 2012. <http://www.irda.org/>.
- [5] T. Komine and M. Nakagawa. Fundamental analysis for visible-light communication system using led lights. *Consumer Electronics, IEEE Transactions on*, 50(1):100 – 107, feb 2004.
- [6] B. University. *Smart Lighting Engineering Research Center*, 2012. <http://www.bu.edu/smartlighting/>.
- [7] A. Vallgrda and T. Sokoler. A material strategy: Exploring material properties of computers. *International Journal of Design*, 4(3):1 –14, 2010.
- [8] J. Vucic, C. Kottke, S. Nerreter, A. Buttner, K.-D. Langer, and J. W. Walewski. White light wireless transmission at 200 mb/s net data rate by use of discrete-multitone modulation. *Photonics Technology Letters, IEEE*, 21(20):1511 –1513, oct.15, 2009.